

USER GUIDE

Evaluation Board

Table of Contents

1	Introduction	2
2	Installation and Usage	3
3	Specifications	5
4	Pinouts and Drawings	6
4.1	Type 9001	6
4.2	Type 9002	8
4.3	Type 9003	10
5	Driver and Cable Compatibility	12
5.1	Type 9001	12
5.2	Type 9002	12
5.3	Type 9003	13
6	Using with commercial mounts for cooling	14
7	Additional Notes	15
8	Appendix	17
8.1	<i>mini</i> TA pinout and package drawing	17
8.2	μ MOPA pinout and package drawing	18
9	Product Contents	19

1 Introduction

For easy start-up of our new 14-pin Butterfly based products like the *miniTA* and the μ MOPA we provide a simple evaluation board (Evaluation Board). With the Evaluation Board we have created a way to handle both the thicker pins (\varnothing 0.8 mm) and the high thermal dissipation of the *miniTA* and μ MOPA series.

With the specially adapted contact terminals, we can guarantee up to 5 A per pin. High thermal heat loss can be effectively dissipated via the gold-plated cooling plate made of high-purity copper. It provides passive cooling with very low K/W thermal rise.

No soldering is required for simple plug and play operation. To ensure an easy start-up we provide three versions of the Evaluation Board. The first version 9001 is fully compatible with laser and TEC drivers from Arroyo and ILX. With the 9002 version you can start directly with your drivers and cables from Thorlabs. If you need a manufacturer independent driver and cable configuration you can switch to version 9003. This one also provides up to 10 A per pin for the laser current, which is required for the μ MOPA.

Features at a glance:

- Simple contacting via contact clamps
- CW and QCW up to 5 A per contact (up to 100 μ s pulse width)
- Gold-plated copper mount with low thermal resistance for high heat loads
- Plug and play with commercially available laser and TEC drivers
- Compatible with industry grade laser mounts for high cooling performance
- Free and wide access to the butterfly window and thus to the beam output
- No soldering necessary

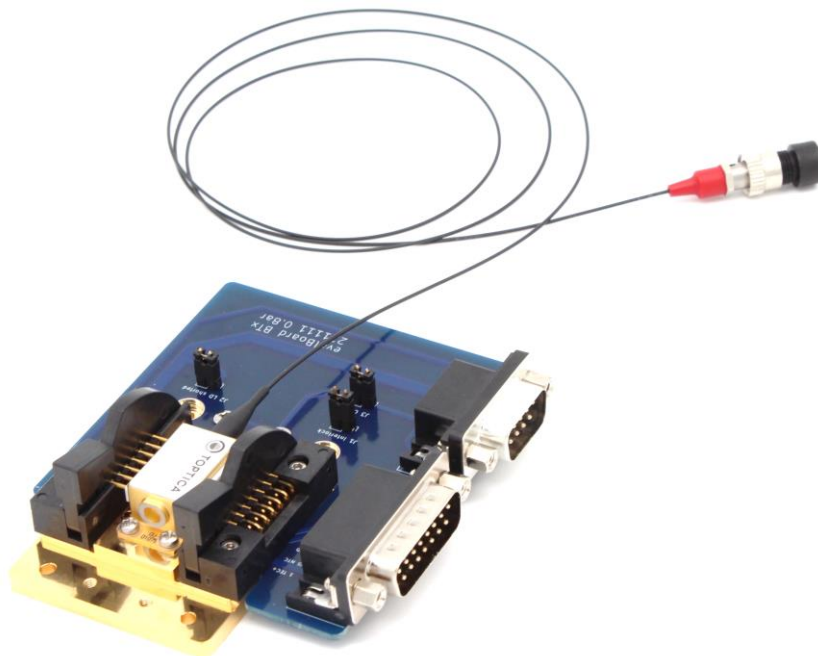

Figure 1 Evaluation Board version 9001

2 Installation and usage

Before first use, please make sure that all parts and screws are present (see chapter 9). For effective cooling of the laser, please mount the Evaluation Board cooling plate on a suitable heat sink or cooler (see also chapter 6). Please consider the required beam height. Next, connect the existing cables to the laser and TEC driver.

NOTE: Make sure that the current limits on the TEC and laser drivers are set to the maximum values in the laser data sheet. In general, no more than 5 A should be set for versions 9001 & 9002 and 10 A for version 9003.

If possible, use the laser and TEC drivers recommended in this manual as well as the appropriate cables (see chapter 5).

The board is equipped with several jumpers. Please also refer to chapter 4.

NOTE: Jumper J2 should be plugged in for ESD protection when mounting the laser. However, it must be removed when you run the laser.

Place the laser in the middle of the gold-plated cooling plate. The pins should be in the pockets of the contact terminals on both sides. Pins 1 and 14 should face forward with the window. Screw the laser onto the cooling plate using the provided M2.0 screws. Make sure that the tightening forces do not exceed 0.2 Nm. If possible, tighten the screws iteratively diagonally and crosswise. Please also refer to our APP Note ([link](#)).

Once the butterfly case is screwed tight, you can close the contact clamps. Before running the laser, disconnect jumper J2 and, if necessary, connect jumper J1 to interlock the laser drivers.

NOTE: To monitor the temperature of the butterfly housing and the cooling plate, an additional thermistor can be mounted in the Ø 2.5 mm hole of the cooling plate below the butterfly package. Simply contact us if you would like to have this pre-mounted by us.

WARNING: The cooling plate can become very hot during operation and can cause burns to the skin or other objects. Therefore, always ensure good cooling of the Evaluation Board.

CAUTION: Be sure you are properly ESD protected before handling the laser. For additional information please read the ESD information in the data sheet of the respective laser.

3 Specifications

Parameter	Symbol	Unit	min	typ	max	Comment
Storage Temperature	T_s	°C	-40		+85	
Operational Temperature	T_{op}	°C	15		50	non-condensing
Laser Current Type 9001 & 9002	I_{LD}				5	CW & QCW
Laser Current Type 9003	I_{LD}				10	CW & QCW
TEC Current	I_{TEC}				5	
Size (HxWxD)		mm	80.8 x 96.3 x 25.4			including connectors
Weight		kg		0,17		including connectors

Table 1 Technical Specifications

Evaluation Board Typ	Input Connector Typ Laser	Input Connector Typ TEC	Comment
9001	9-Pin D-Sub male	15-Pin D-Sub male	max 3 A per connector pin
9002	9-Pin D-Sub female	9-Pin D-Sub male	max 3 A per connector pin
9003	Screw Terminal	Screw Terminal	max 5 A per Screw Terminal max 10A for Pin 15 & 16 only

Table 2 Input Connectors

4 Pinouts and Drawings

4.1 Type 9001

DB-9 Pin	Description	Corresponding Butterfly Pin
1 & 2	Interlock	-
3	Case Ground	13*
4 & 5	Laser Cathode	11 & 12
6	Photodiode (PD) Cathode	4
7	Photodiode (PD) Anode	3
8 & 9	Laser Anode	9 & 10

Table 3 Laser Connector DB-9 Pin-out (male) for type 9001

* If Case Jumper J3 is plugged in

DB-15 Pin	Description	Corresponding Butterfly Pin
1 & 2	TEC +	1
3 & 4	TEC -	14
7	Butterfly Thermistor	2
8	Butterfly Thermistor	4
5, 6, 9, 10-15	Not Connected	-

Table 4 TEC Connector DB-15 Pin-out (male) for type 9001

USER GUIDE

Jumper	Description	Notes
J1 Interlock	Closes the interlock circuit	See laser diver manual
J2 LD shorted	Short-circuit Pin 9/10 (laser anode) with pin 11/12 (laser cathode).	ESD laser protection
J3 Case	Butterfly Case to Case Pin	See laser diver manual

Table 5 Jumper configuration for type 9001

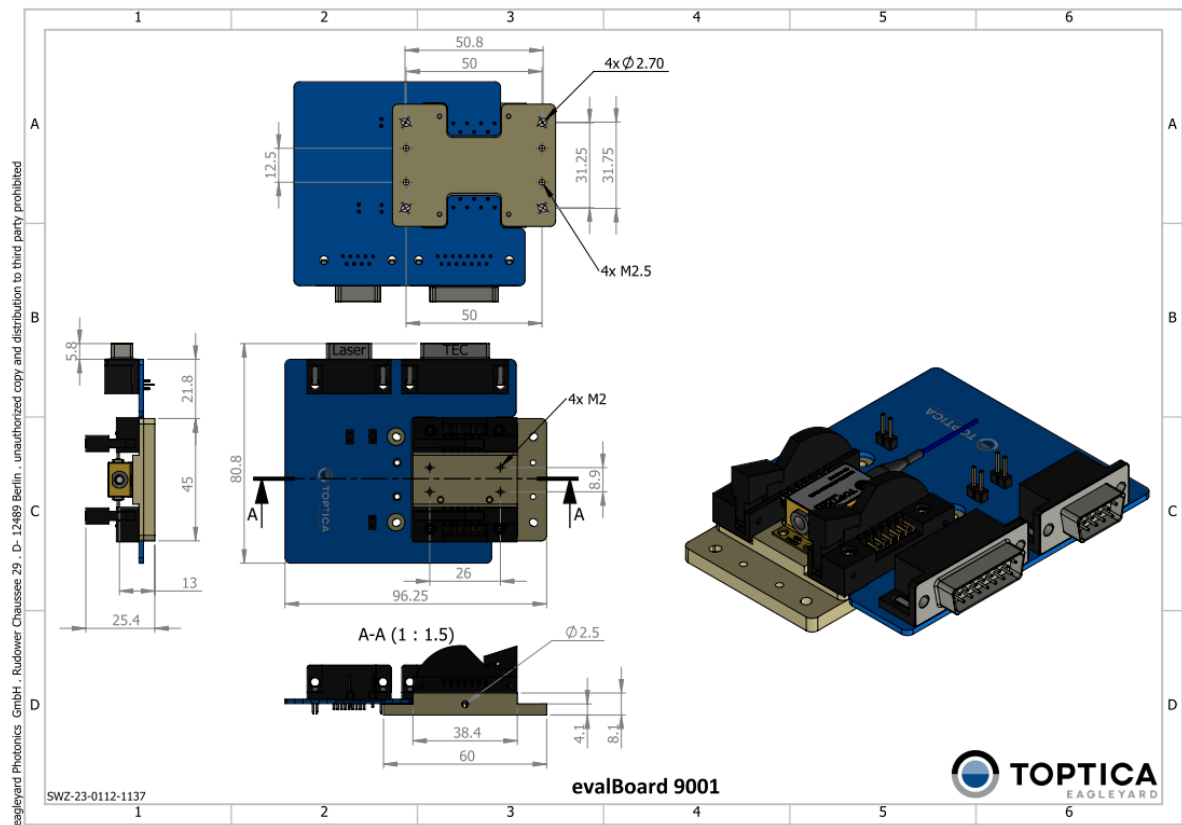

Figure 2 Evaluation Board 9001 interface drawing

4.2 Type 9002

Pin	Description	Corresponding Butterfly Pin
1	Interlock +	-
2	Photodiode (PD) Cathode -	4
3	Laser Cathode Ground	11 & 12
4	Photodiode (PD) Anode +	3
5	Interlock -	-
6	Voltage Sense Laser Cathode	11 & 12
7	Not Connected	-
8	Laser Diode Anode <i>(with polarity cathode grounded CG (+))</i>	9 & 10
9	Voltage Sense Laser Diode Anode	9 & 10

Table 6 Laser connector DB-9 Pin-out (female) for type 9002

Pin	Description	Corresponding Butterfly Pin
1	Not Connected	-
2	Butterfly Thermistor	2
3	Butterfly Thermistor	5
4	TEC +	1
5	TEC -	14
6, 7, 8, 9	Not Connected	-

Table 7 TEC connector DB-9 Pin-out (male) for type 9002

Jumper	Description	Notes
J1 Interlock	Closes the interlock circuit	See laser diver manual
J2 LD shorted	Short-circuit Pin 9/10 (laser anode) with pin 11/12 (laser cathode).	ESD laser protection
J3 Case to LD Ground	Butterfly Case to LD Ground	See laser diver manual

Table 8 Jumper configuration for type 9002

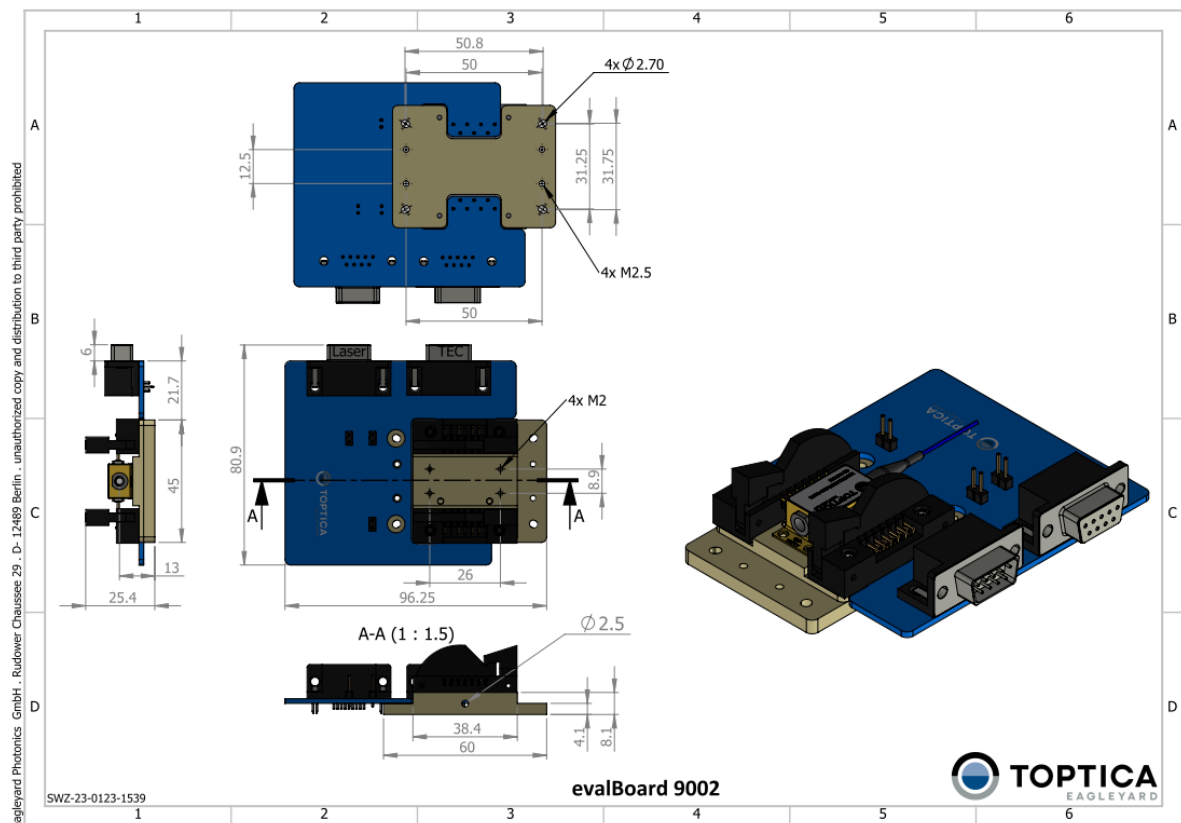

Figure 3 Evaluation Board 9002 interface drawing

4.3 Type 9003

Pin	Description	Corresponding Butterfly Pin	Notes
1	TEC+	1	max 5 A (AWG 22 – 16)
2	TEC-	14	max 5 A (AWG 22 – 16)
3	Butterfly Thermistor	2	
4	Butterfly Thermistor	5	
5	Photodiode (PD) Anode +	3	
6	Photodiode (PD) Cathode -	4	
7	μ MOPA DBR- Anode Voltage Sense	7	
8	μ MOPA DBR+ Cathode Voltage Sense	6	
9	μ MOPA DBR+ Cathode	6	
10	μ MOPA DBR- Anode	7	
11	Case	13	If Case Jumper J3 is plugged in
12	Not connected	-	
13	TA+ Voltage Sense Anode	9 & 10	
14	TA- Voltage Sense Cathode	11 & 12	
15	TA- Cathode	11 & 12	max 10 A (AWG 12)
16	TA+ Anode	9 & 10	max 10 A (AWG 12)

Table 9 Laser & TEC Screw Terminal for type 9003

Jumper	Description	Notes
J2 LD shorted	Short-circuit Pin 9/10 (laser anode) with pin 11/12 (laser cathode).	ESD laser protection
J3 Case	Butterfly Case to screw terminal #11	See laser diver manual

Table 10 Jumper configuration for type 9003

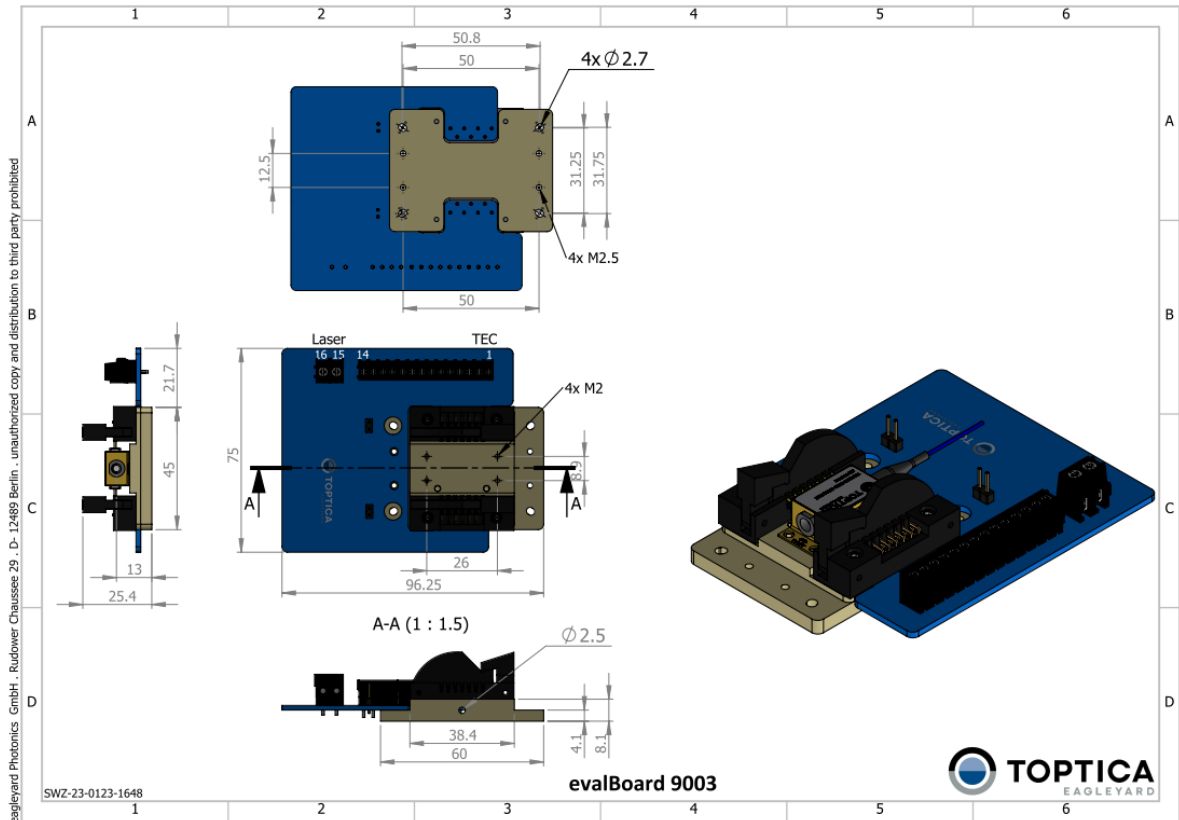

Figure 4 Evaluation Board 9003 interface drawing

5 Driver and Cable Compatibility

Below you will find a list of compatible drivers and cables depending on the Evaluation Board type. To verify the compatibility of further drivers and cables please check our requirements and pin-outs.

5.1 Type 9001

Driver	Cable
Arroyo 6340 ComboSource, 4 Amp	1220B LaserSource Cable 1260B TECSOURCE Cable
Arroyo 4304-(QCW) LaserSource, 4A	1220B LaserSource Cable
Arroyo 5240 TECSOURCE, 4A/7V	1260B TECSOURCE Cable
Arroyo 5305 TECSOURCE, 5A/12V	1260B TECSOURCE Cable
mks (ILX) LDC-3736 4A/18V	1220B LaserSource Cable 1260B TECSOURCE Cable

Table 11 Driver and cable compatibility for Evaluation Board type 9001

5.2 Type 9002

Driver	Cable
ITC4005 Laser Diode/TEC Controller, 5 A	CAB4005 13W3 to D-Sub-9, 5 A CAB4000 17W2 to D-Sub-9, 5 A
LDC240C LD Current Controller, 4 A	CAB400 D-Sub-9, 5 A
LDC8040 Laser Diode Current Control Module, ± 4 A (PRO800 Chassis needed)	CAB400 D-Sub-9, 5 A
TED8040 Laser Diode Current Control Module, ± 4 A (PRO800 Chassis needed)	CAB420-15 D-Sub-15 to D-Sub-9

Table 12 Driver and cable compatibility for Evaluation Board type 9002

5.3 Type 9003

Diver	Cable
Thorlabs ITC4020 Laser Diode/TEC Controller, 20 A	Connector Kit CON4001 & CON4005
4308-(QCW) LaserSource, 8A, (QCW)	1221B LaserSource Cable, 4A, 2m, Pigtailed
Arroyo 4400-10-56 LaserSource, 10A/56V	1231 LaserSource Cable, 13W3, 20A, Pigtailed
Arroyo 4320-(QCW) LaserSource, 20A, (QCW)	1229C LaserSource Cable, 20A, 2m, Pigtailed
Arroyo 5240 TECSOURCE, 4A/7V	1261B TECSOURCE Cable, 5A, Pigtailed, 2m
Arroyo 5305 TECSOURCE, 5A/12V	1261B TECSOURCE Cable, 5A, Pigtailed, 2m

Table 13 Driver and cable compatibility for Evaluation Board type 9003

6 Using with commercial mounts for cooling

To provide a good thermal management of the laser, the cooling plate of the Evaluation Board should be mounted on a suitable heat sink. For this purpose, the base plate offers 4x \varnothing 2.5 mm holes which are suitable for metric screws (M2.5) and a distance of 50 mm \times 31.25 mm as well as for imperial screws like UNC 2-65 at a distance of 2" \times 1.25". Thus, the Evaluation Board is fully compatible with the Arroyo LaserMount 260 series for both a metric and an imperial bread board cold plate, which offers a thermal capacity of up to 30 W.



Figure 5 Evaluation Board at Arroyo 264-BB LaserMount

If you plan to use the *miniTA* or μ MOPA on an optical table, a passive aluminium heat sink is generally sufficient. Please contact us, we will find a suitable solution.

The following figure shows the typical heat loss of a *miniTA* on an ideal heat sink (temperature controlled and water cooled) at 25°C. Please note that the heat loss will be significantly higher when using passive heat sinks with higher thermal resistance (R_{th}).

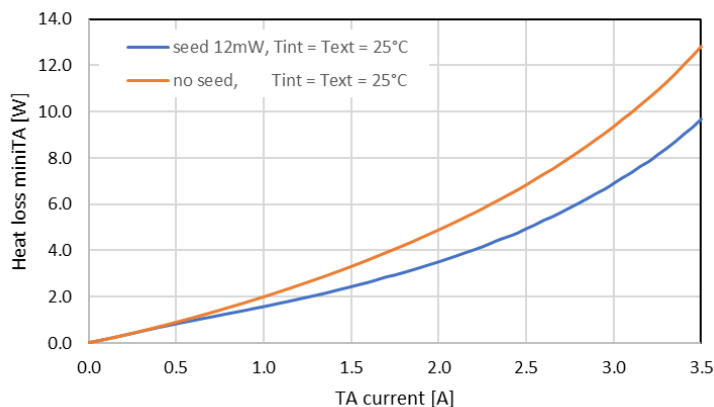

Figure 6 *miniTA*: total heat loss in seed and without seed operation mode

7 Additional Notes

The Evaluation Board has been optimized for the new product variants *miniTA* and μ MOPA with thicker pins. However, it is also fully compatible with the lasers offered by EAGLEYARD in the 14-pin butterfly package, which are marked with the std. pinning x2 in the product code. For a detailed overview of the compatibility of different EAGLEYARD products with the Evaluation Board see Table 14. Please note that the earlier *miniTA* with the product label BFU09 must be rotated by 180°C because of the pin assignment. In that case the laser emission of the *miniTA* BFU09 is guided across the Evaluation Board.

Product Evaluation Board Version	9001 D-Sub Connector Arroyo / ILX Pin-out	9002 D-Sub Connector Thorlabs Pin-out	9003 Screw Terminal	Note
<i>miniTA</i>	✓	✓	✓	max 5 A
<i>μMOPA</i>			✓	max 10 A, 2 Sections
TPA-BFU	✓	✓	✓	180° turned
BFYx2	✓	✓	✓	
				

Table 14 Evaluation Board version and compatibility

8 Appendix

8.1 *miniTA* pinout and package drawing

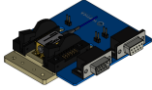
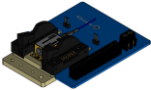
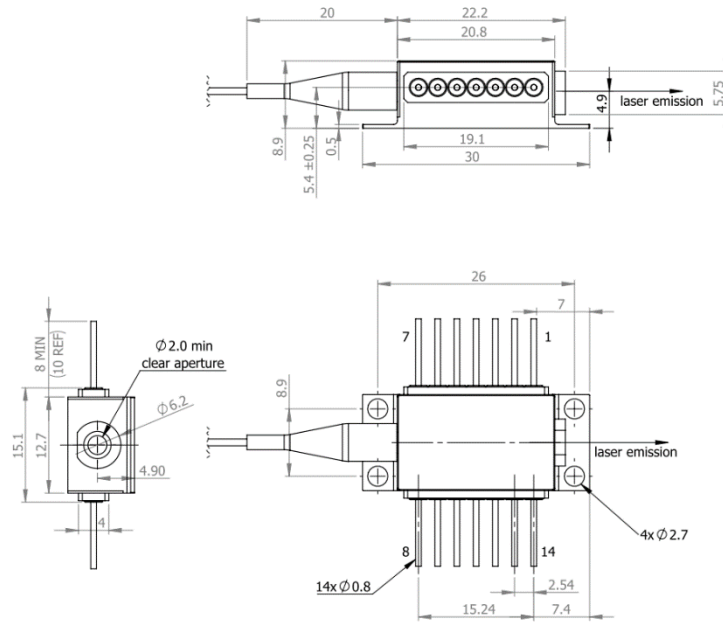

Figure 7 *miniTA* package drawing (new BTU-version)

1 Thermoelectric Cooler (+)	14 Thermoelectric Cooler (-)
2 Thermistor	13 not connected
3 not connected	12 not connected
4 not connected	11 Amplifier (Cathode)
5 Thermistor	10 Amplifier (Anode)
6 not connected	9 not connected
7 not connected	8 not connected

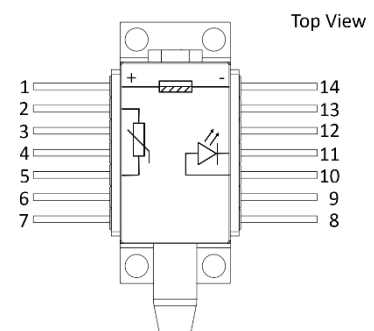

Figure 8 *miniTA* package pinning (new BTU-version)

8.2 μ MOPA pinout and package drawing

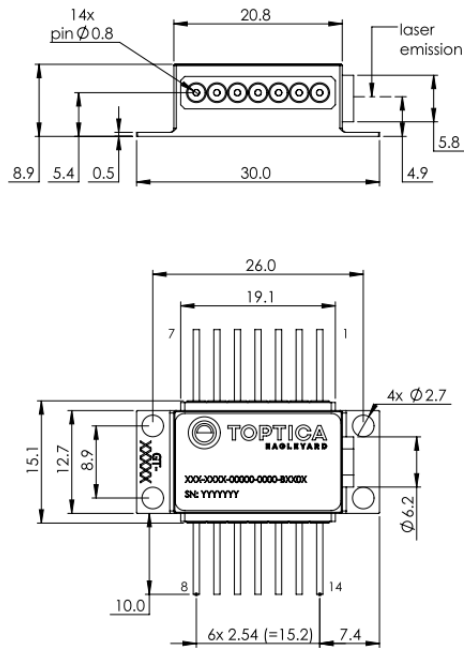

Figure 9 μ MOPA package drawing (new BTW-version)

1	Thermoelectric Cooler (+)	14	Thermoelectric Cooler (-)
2	Thermistor +	13	not connected
3	not connected	12	Amplifier Cathode
4	(Thermistor +)	11	Amplifier Cathode
5	Thermistor -	10	Amplifier Anode
6	DBR Laser Cathode	9	Amplifier Anode
7	DBR Laser Anode	8	not connected

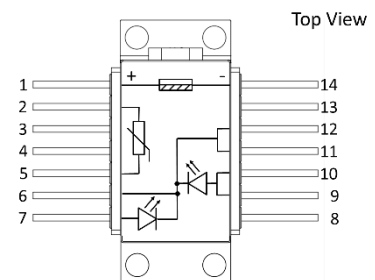

Figure 10 μ MOPA package pinning (new BTW-version)

9 Product Contents

Part	Description
PCB	Printed Circuit Board
Coldplate	Mounting Plate for butterfly and cooling
D-Sub Connectors	preinstalled
Test Tocket	preinstalled
Screws	For mounting of the butterfly package and the Evaluation Board
Jumper	For case, interlock and ESD protection

Table 15 Product Contents